

SCHÉMA ZAPOJENIA

TORRETTE TR-E

TRM 10/15/20/30/50
(s ovládačom IRM)

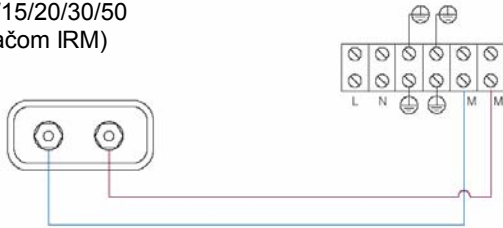

TRM 70
(s ovládačom IRM)

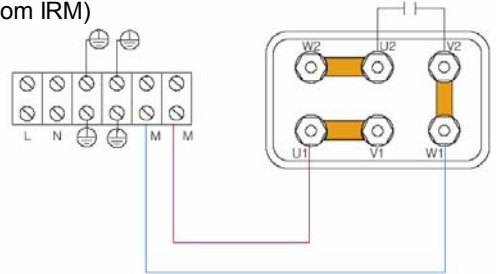

TRM 10/15/20/30/50
(s ovládačom IREM)

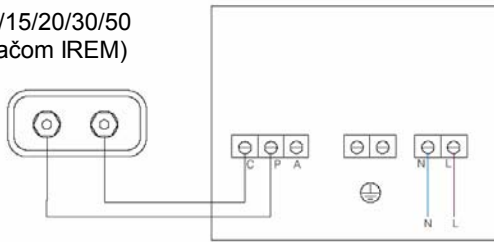

TRM 70
(s ovládačom IREM)

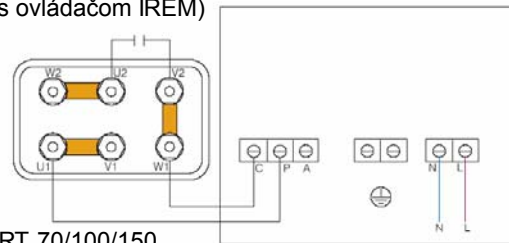

TRT 10/15/20/30/50
(s ovládačom IRT)

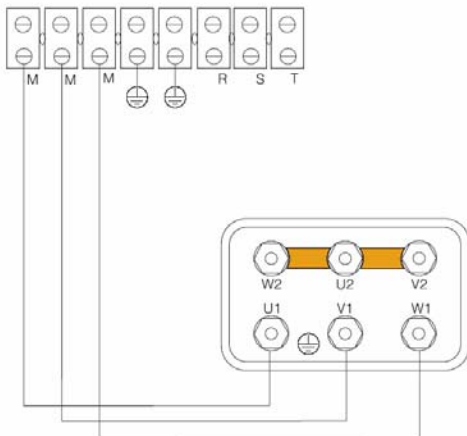

TRT 70/100/150
(s ovládačom IRET 6)

